



e -TENDER DOCUMENT

FOR

PROCUREMENT OF TLM ON MATHEMATICS

DECEMBER 2021

Bid reference no. 12684/PED/2021 dated.24/12/2021

**ODISHA SCHOOL EDUCATION PROGRAMME AUTHORITY
SHIKHYA SOUDH, UNIT-V, BHUBANESWAR-751001.**

Web site : osepa.odisha.gov.in

CONTENTS OF THE BID DOCUMENT

SI No.	Description of contents	Page Number
1.	Notice Inviting Tender	03
2.	Disclaimer	04
3.	Section – 1 : Information to the Bidder/s	05-06
4.	Section - 2 : General Definition & Scope of Contract	07
5.	Section - 3 : Bid Schedule.	08
6.	Section - 4 : Special Conditions of Contract.	09-10
7.	Section - 5 : General Conditions of Contract.	11-23
8.	Section - 6 : Technical Specifications	24-49
9.	Section - 7 : Formats of Technical bid.	50-54
10.	Section- 8 : Annexures.	55-59



ODISHA SCHOOL EDUCATION PROGRAMME AUTHORITY

“SHIKSHA SOUDHA”, UNIT-V, BHUBANESWAR-751001

Phone - 2395325, FAX-2392721. Web site - osepa.odisha.gov.in, E mail-opepaedu@yahoo.co.in

NOTICE INVITING TENDER (NIT)

Bid reference No: 12684/PED/2021

Dated: 24/12/2021

M (MK)-454/18

Odisha School Education Programme Authority (OSEPA), a Society under administrative control of School and Mass Education Department, Govt. of Odisha invites **online Bids** through e-Tender portal (<https://tendersodisha.gov.in>) from eligible bidders for Procurement of “Teaching Learning Material on Mathematics” as per the particulars mentioned below.

Sl.no	Particulars	Date and time
1	Date & time of release of bid	12 : 30 PM of 29/12/2021
2	Date & time of Online bid submission	Up to 11 AM of 20/01/2022
3	Cost of tender paper / Bid processing fee (non -refundable)	Rs.5,000/- (on - line)
4	EMD / Bid security	Not asked for (only declaration to be submitted)
5	Date and time of Pre Bid meeting	11:30 AM of 10/01/2022
5	Date & time of online Technical bid opening	12 noon of 20/01/2022
6	Last date and time for submission of Sample	Up to 11 AM of 20/01/2022 (off-line mode through post / courier only to be received by issue/despatch section of OSEPA in all working days excluding Sundays and Government holidays)
7	Date of opening of Financial Bid	To be informed to the technically qualified bidders.

The bid document with all information relating to the bidding process including cost of bid document, prequalification criteria and terms & conditions etc are available in the websites: osepa.odisha.gov.in and <https://tendersodisha.gov.in>. Corrigendum / addendum, if required, will be uploaded in the above web site. Hence potential bidders are requested to be in continuous touch with the above web site. The Tender Inviting Authority i.e. OSEPA reserves the right to accept / reject any / all bids / cancel the entire selection process at any stage without assigning any reason thereof. No claim, whatsoever, shall be admissible for the alleged loss/damage suffered by the bidders on account of such rejections.

-sd-

State Project Director

Memo No. 12685/Ped/21

Date. 24/12/2021

Copy forwarded to Principal Secretary to Government School & Mass Education Department for Kind information.

-sd-

State Project Director

Memo No. 12686/Ped/21

Date. 24/12/2021

Copy forwarded to the State Head Portal, IT Cell, Odisha Secretariat, Bhubaneswar for information.

-sd-

State Project Director

Memo No. 12687/Ped/21

Date. 24/12/2021

Copy forwarded to the Chief Manager (Technical), State Procurement Cell, Nirman Saudha, Bhubaneswar for information.

-sd-

State Project Director

DISCLAIMER

The e-Tender is issued by the Odisha School Education Programme Authority (OSEPA), a society under administrative control of School & Mass Education Department, Govt. of Odisha for procurement of **“Teaching Learning Material (TLM) on Mathematics”**. While the information in this Bid document has been prepared in good faith, it does not support to be comprehensive or to have been independently verified. Neither OSEPA nor any of its officers or employees, accept any liability or responsibility for the accuracy, reasonableness or completeness of ,or for any errors, omissions or misstatements, negligent or otherwise, relating to the proposed assignment, or makes any representation or warranty, express or implied, with respect to the information contained in this Bid Document or on which this Bid Document is based or with respect to any written or oral information made or to be made available to any of the recipients or their professional advisers and, so far as permitted by law and except in the case of fraudulent misrepresentation by the party concerned, and liability therefore is here by expressly disclaimed.

The information contained in this Bid document is selective and subject to updating, expansion, revision and amendment at the sole discretion of the OSEPA. It does not claim to contain all the information that a recipient may require for the purposes of making a decision for participation in this selection process. Each bidder/s must conduct its own analysis of the information contained in this Bid Document, to correct any inaccuracies there in and is advised to carry out its own investigation into the proposed assignment, the regulatory regime which applies there to and by and all matters pertinent to the project and to seek its own professional advice on the legal, financial and regulatory consequences of entering into any agreement or arrangement relating to the project.

This Bid document includes certain statements, information, projections and forecasts with respect to the proposed assignment. Such statements, information, projections and forecasts reflect various assumptions made by the management, officers and employees of the OSEPA, which the assumptions and the base information on which they are made may or may not prove to be correct. No representation or warranty is given as to the reasonableness of forecasts or the assumptions on which they may be based and nothing in this Bid Document is, or should be relied on as, a promise, representation or warranty.

OSEPA shall be the sole and final Authority with respect to selection of a bidder/s through this tender.

SECTION: 1

INFORMATION TO THE BIDDER/S

- 1.1 Odisha School Education Programme Authority (OSEPA) a Society under administrative control of School and Mass Education Department, Govt. of Odisha invites BID from the eligible bidder/s for Procurement of “**Teaching Learning Material on Mathematics**” .
- 1.2 This BID document includes the following :
- a. **Disclaimer**
 - b. **Section - 1** : Instruction to the Bidder/s.
 - c. **Section - 2** : General Definition & Scope of Contract
 - d. **Section - 3** : Bid Schedule.
 - e. **Section - 4** : Special Condition of Contract.
 - f. **Section - 5** ; General Condition of Contract.
 - g. **Section - 6** : Technical Specifications.
 - h. **Section -7** : Technical Bid formats.
 - i. **Section - 8** Annexures.
- 1.3 The bid document published by the Bid Inviting Officer (Procurement Officer-Publisher) in the e-procurement portal <https://tendersodisha.gov.in> will appear in the “Latest Active Tender”. The Bidder/s/ Guest Users can download the Bid documents from <https://tendersodisha.gov.in> and submit it online from **12:30 PM of 29/12/2021 to 11 AM of 20/01/2022** after which the same will be removed from the list of “Latest Active Tender”. The bid document is also available at web site: osepa.odisha.gov.in.

1.4 PARTICIPATION IN BID

1.4.1 PORTAL REGISTRATION:

The bidder/s intending to participate in the bid is required to **register in the e-procurement portal** using an active personal/official e-mail ID as his/her Login ID and attach his/her valid **Digital signature certificate (DSC) – Class II or III** to his/her unique Login ID. He / She have to submit the relevant information as asked for about the bidder/s. The portal registration of the bidder/s is to be authenticated by the **State Procurement Cell** after verification of original valid certificates/documents such as (i) PAN and (ii) Registration Certificate (RC) / GST Registration Certificate of the concerned bidder/s. The time period of validity in the portal is at par with validity of RC. Any change of information by the bidder/s is to be re-authenticated by the State Procurement Cell. After successful authentication, bidder/s can participate in the **online bidding process**.

1.4.2 - LOGGING TO THE PORTAL:

The Bidder/s is required to type his/her Login ID and password. *The system will again ask to select the DSC and confirm it with the password of DSC as a second stage authentication.* For each login, a user's DSC will be validated against its date of validity and also against the **Certificate Revocation List (CRL)** of respective CAs stored in system database. The system checks the unique Login ID, password and DSC combination and authenticates the login process for use of portal.

1.4.3 - DOWNLOADING OF BID:

The bidder/s can download the bid of his / her choice and undertake the necessary preparatory work **off-line** and upload the completed bid at their convenience before the closing date and time of submission.

1.4.4 - CLARIFICATION ON BID:

The registered bidder/s can ask questions related to online bid in the e-procurement portal through email: osepaedu@yahoo.co.in , tpedagogy@gmail.com.

1.4.5 - PREPARATION OF BID

The detail guideline for preparation of bid is mentioned at General condition of Contract- **Section- 5 (Clause 5.10)**. .

1.4.6 - PAYMENT OF COST OF BID DOCUMENT:

The detail guideline for payment of Cost of Bid Document is mentioned at General Condition of Contract- Section 5. (**Clause 5.2.5**).

1.4.7- SUBMISSION AND SIGNING OF BID.

The detail guideline for submission of & signing of bid is mentioned at General Condition of Contract- Section 5 (**Clause 5.12**).

SECTION: 2

GENERAL DEFINITION & SCOPE OF CONTRACT

2.1 General Definitions:

- 2.1.1 Department means School & Mass Education Department, Government of Odisha.
- 2.1.2 Central Govt. means Government of India. State/UT Government means any Government of state/UT of India.
- 2.1.3 Govt/Govt aided organisation means Central/State/UT Government. /aided organisation in India.
- 2.1.4 Authority means Odisha School Education Programme Authority.
- 2.1.5 OSEPA means Odisha School Education Programme Authority.
- 2.1.6 DEO means District Education Officer.
- 2.1.7 DPC means District Project Co-ordinator.
- 2.1.8 BEO means Block Education Officer.
- 2.1.9 Bid / Tender Inviting Authority is the State Project Director, Odisha School Education Programme Authority (OSEPA) or authorized person of State Project Director, Odisha School Education Programme Authority (OSEPA).
- 2.1.10 *Bid Evaluation Committee & Technical Committee* are Committees authorized by the Government / Principal Secretary to Govt. School and Mass Education Department / State Project Director OSEPA to recommend the purchase of the Teaching Learning Material on Mathematics”.
- 2.1.11 *Blacklisting / debarring* – the event occurring by the operation of the conditions under which the bidder/s will be prevented for a period of 3 years from participating in the future bids of Tender Inviting Authority, more specifically mentioned in the Special Conditions of Contract (Section - 4) and General Conditions of Contract (Section - 5) of this bid document, the period being decided on the basis of number of violations in the bid conditions and the loss / hardship caused to the Tender Inviting Authority on account of such violations. In case of violation of bid conditions / contract, the Tender Inviting Authority may write Government for blacklisting the bidder/s/supplier.

2.2 Scope

The bid is invited for the Procurement of the Teaching Learning Material on Mathematics to be distributed free of cost to the Government Schools with Primary Section of 08 districts, all 30 districts having primary section under SC/ST Development Schools & all DIETs of the State of Odisha.

- 2.2.1 The bidder/s can't withdraw their bid after opening of technical bid, within the minimum bid validity period of 90 days from the date of opening of the financial bid & also after accepting the supply order.
- 2.2.2 Withdrawal or non-compliance of agreed terms and conditions after the execution of agreement will lead to invoking of penal provisions and may also lead to blacklisting.

SECTION: 3
BID SCHEDULE
BIDDER DATA SHEET

S. No.	Particular	Details
1	Tender Inviting Authority	Odisha School Education Programme Authority (OSEPA), Unit-V, Bhubaneswar-751001.
2	Bid Reference No	12684/PED/2021 dated.24/12/2021
3	Availability of the Tender Paper	https://tendersodisha.gov.in and osepa.odisha.gov.in
4	Mode of Submission of Bid	Online through e-Tender portal (https://tendersodisha.gov.in)
5	Date and time of Issue of the Bid	12 : 30 PM of 29 /12/2021
6	Date / time and venue of Pre Bid Meeting	11 :30 AM of 10/01/2022 at Conference hall of OSEPA
7	Last date and time of online bid submission	up to 11 AM of 20/01/2022
8	Date & time of online opening of Technical BID	12 noon of 20/01/2022
9	Last date and time of Submission of Sample bag Teaching Learning Material on Mathematics”	Up to 11 AM of 20/01/2022 (off-line mode through post / courier only to be received by issue/despatch section of OSEPA in all working days excluding Sundays and Government holidays)
10	Date of opening of Financial BID	To be informed to the technically qualified bidders
11	Cost of tender paper / Bid Processing Fee (Non-Refundable)	Rs.5,000/- (Rupees Five Thousand) only (on-line mode)
12	Earnest Money Deposit (EMD) / Bid Security Deposit	Not asked for (only declaration to be submitted)
13	Point of Delivery & Date for Completion of supply	District points & at State Project Office within 100 days from the date of issue of supply order letter from OSEPA
14	Validity of Bid	90 days from the date of opening of Financial Bid.
15	Performance Security	03 % of the value of the Contract to be given by the successful bidder.
16	Validity of performance security	The performance security (in case of Bank Guarantee) shall remain valid for a period of minimum (01) one year from the date of issue of supply order.

SECTION: 4

SPECIAL CONDITIONS OF CONTRACT

4.1 Time Limits Prescribed

Sl.no	Activity	Time Limit
4.1.1	Delivery period	District points within 100 days from the date of issue of supply order letter from OSEPA. For detail please refer Clause no. 5.17 & 5.18 of General Condition of Contract.
4.1.2	Submission of performance security and signing the contract agreement	Within 07 days from the date of issue of the supply order.
4.1.3	Release of Payment	For details please refer Clause no 5.19 of General Conditions of Contract.

4.2 Eligibility / Pre-qualification criteria:

- 4.2.1 Tenders is invited from Manufacturer or Supplier or Company having legal status.
- 4.2.2 The bidder/s must have valid registration under Goods and Services Tax (GSTIN) and Income Tax PAN/TAN.
- 4.2.3 The bidder/s of Odisha State must have the GST Registration Certificate issued by the Competent Authority of Odisha along with the GST returns (GSTR-3B and GSTR-1) filed for the last Tax period. Similarly, the bidder/s from outside State must have the GST Registration Certificate, copy of GST Return of last Tax period. The bidder/s from outside state is to furnish an affidavit as per format enclosed at **Annexure-A**.
- 4.2.4 The bidder/s must have annual turnover of Rs.3.00 crore or more in any one of the last 3 financial years i.e. 2018-19,2019-20 & 2020-21. For this, the bidder/s submit (i) Income Tax Return, (ii) Audited Balance sheet, Profit & Loss account, Trading Account duly certified by Chartered Accountant for the year in which the annual turnover is Rs.3.00 crore or more in any one of the last 03 financial years i.e. 2018-19,2019-20 & 2020-21. For local MSEs / Start-ups , the prior turnover is relaxed / waved as per Government guidelines.
- 4.2.5 The bidder/s must have minimum one contract of supplying Educational Kit / Math Kits / Science kits / or equivalent Teachig or Learning materials to Govt./Govt aided organization in any one of years from 2018-19 to 2021-22.The minimum size of uch contract should have been for supply of 1000 units of any type of Educational kit / equivanent Teaching or learning materials. For local MSEs / Start-ups , the prior turnover is relaxed / waved as per Government guidelines
- 4.2.6 The bidder/s shall furnish one set of sample Teaching Learning Material on Mathematics in off-line mode only through Post or Courier confirming to the tendering specifications narrated in section-6 of the bid document. The sample Kits should comprise of all items mentioned in Serial No.1 to 20 and A4 size paper used for printing of Teacher's Manual (Item no.23) of the Technical Specifications mentioned in Section-6 of the bid document. **Submission of more than one set of sample will not be accepted & lead to rejection of the bid.** Submission of samples in English language, wherever Odia is specified, will also be accepted only for technical bid evaluation purpose.

- 4.2.7 The bidder/s will also submit test report against Point No.5 i.e. Material only in case of items mentioned in Serial No.1 to 20 of the Technical Specification narrated in Section-6 of the Bid document. In this respect the said test report shall be obtained from any Govt. testing Laboratory (State Govt /Central Govt /UT Govt) **or** from any NABL Accredited Testing laboratory of India.
- 4.2.8 Bidder/s is to ensure that any input material, ink & color used in manufacture and printing should be non-toxic conforming to FSS Act 2006 and Food & Drug Authority rule. Bidder/s should submit Test Certificate confirming to IS 9873 (Part 3) or ISO 8124-3 for the materials used in the manufacturing from any Government Testing Laboratory (State Govt /Central Govt /UT Govt) **or** from any NABL Accredited Testing laboratory of India.
- 4.2.9** The bidder/s shall have to submit EMD / Bid security declaration as per prescribed format and cost of the Tender paper / bid processing fee as mentioned in the e-tender document.
- 4.2.10 The bidder/s who has been blacklisted / debarred / banned by any State Govt. / UT / Central Govt./Govt. organization / Govt. Institution / PSU / Govt. run autonomous body, Society / OSEPA and or convicted by any court of law due to (a) Service or quality supplied (b) submission of fake or forged documents (c) submission of incorrect information/ suppression of vital information and facts / misrepresentation of quality certificates (d) non-performance or non-supply, cannot participate in the tender during the period of blacklisting / debarment / banned.
- 4.2.11 The bidder/s has to submit declaration in prescribed format in shape of an affidavit before Executive Magistrate / Notary Public as per **Annexure-B**.

SECTION: 5

GENERAL CONDITIONS OF CONTRACT

Odisha School Education Programme Authority (OSEPA), a Society under administrative control of School and Mass Education Department, Govt. of Odisha invites **online Bids** through e-Tender portal (<https://tendersodisha.gov.in>) from Eligible bidder/s for Procurement of “Teaching Learning Material on Mathematics” The General Conditions of Contracts as Under.

5.1 **Bid Document availability and submission:**

5.1.1 The detailed technical specifications and terms and conditions governing the supply, quality testing, and payment after supply etc. are contained in this “Bid Document”.

5.1.2 The bid document shall be made available in the website osepa.odisha.gov.in and <https://tendersodisha.gov.in> for downloading. Bidder/s shall submit Cost of tender paper / Bid Processing Fee (mentioned in Section - 3) .Non submission of the same shall be one of the primary reasons for rejection of the tender in the first round.

5.1.3 The documents shall be submitted online through the e-Tender portal <https://tendersodisha.gov.in> for which the Bidder/s have to enrol themselves in the e procurement portal.

5.2. **General Guidelines on e-Tender Process:**

5.2.1 Bidder/s should have a **Class II or III Digital Signature Certificate** (DSC) to be procured from the Registration Authorities (RA). Once, the DSC is obtained, bidder/s have to register in the e-procurement portal <https://tendersodisha.gov.in> for participating in this bid.

5.2.2 Website registration is a one-time process without any registration fees. However, bidder/s has to procure DSC at their own cost.

5.2.3 Bidder/s may contact State Procurement cell help desk **1800-3456765, 0674-2530998** for assistance in this regard.

5.2.4 The e-Tender process comprises the stages viz. downloading the bid document, bid submission (technical cover and financial cover), opening of technical bid and opening of financial bids for the technically qualified bidder/ss.

5.2.5 **Payment of cost of Tender paper (Rs.5, 000/-)**

(Electronic receipt, Accounting and Reporting of Cost of Tender paper.)

5.2.5.1 The State Government have formulated rules and procedures for Electronic receipt, accounting and reporting of the receipt- of Cost of Tender Paper on submission of bids through the e-procurement portal of Government of Odisha i.e. "<https://tendersodisha.gov.in>".

5.2.5.2 Electronic receipt of cost of tender paper has been successfully tested through SBI payment gateway. Now it has been decided to introduce electronic receipt of **Cost of Tender Paper on submission of bids** through payment gateway of designated banks such as SBI / ICICI Bank/HDFC Bank for all Government Departments, State PSUs. Statutory Corporations, Autonomous Bodies and Local Bodies etc. in phases (ANNEXURE-I) at point 5.2.5.14.

The process outline as well as accounting and reporting structure are indicated below:

- (a) It will be carried out through a single banking transaction by the bidder/s for multiple payments like **Cost of Tender Paper on submission of bids**.
- (b) Various payment modes like Internet banking/ NEFT/RTGS of Designated Banks and their Aggregator Banks as well can be accessed by the intending bidder/ss.
- (c) Reporting and accounting of the e-receipts will be made from a single source.
- (d) Credit of receipts into the Government accounts and to the designated Bank account of the participating entities indicated in Para 2 above would be faster.

5.2.5.3 Only those bidder/s who successfully remit their **Cost of Tender Paper on submission of bids would be eligible** to participate in the tender / bid process. The bidder/s with pending or failure payment status shall not be able to submit their bid. Tender inviting authority, State Procurement Cell, NIC, the designated Banks shall not be held responsible for such pendency or failure.

5.2.5.4 Banking arrangement:

Designated Banks (SBI/ICICI Bank/HDFC Bank) payment gateway are being integrated with e-Procurement portal of Government of Odisha (<https://tendersodisha.gov.in>). The Designated Banks participating in **Electronic receipt, accounting and reporting of Cost of Tender Paper on submission of bids** will nominate a Focal Point Branch called e-FPB, who is authorized to collect and collate all e-Receipts. Each such branch will act as the Receiving branch and Focal Point Branch notwithstanding the fact that the bidder/s might have debited his account in any of the bank's branches while making payment.

5.2.5.5 Procedures of bid submission using electronic payment of tender paper cost by bidder/s:

- (a) **Log on to e-Procurement Portal:** The bidder/s have to log onto the Odisha e-Procurement portal (<https://tendersodisha.gov.in>) using his/her digital signature certificate and then search and then select the required active tender from the "Search Active Tender" option. Now, submit button can be clicked against the selected tender so that it comes to the "My Tenders" section.
- (b) **Uploading of Prequalification/Technical / Financial bid:** The bidder/s have to upload the required Prequalification /Technical/Financial bid, as mentioned in the bidding document.
- (c) **Electronic payment of tender paper cost :** Then the bidder/s has to select and submit the bank name as available in the payment options.
 - (i) A bidder/s shall make electronic payment using their internet banking enabled account with designated Banks or their aggregator banks.
 - (ii) A bidder/s having account in other Banks can make payment using NEFT/RTGS facility of designated Banks.
 - Online NEFT/RTGS payment using internet banking of the bank in which the bidder/s holds his account, by adding the account number as mentioned in the challan as an interbank beneficiary.
- (d) **Bid submission:** Only after receipt of intimation at the e-Procurement portal regarding successful transaction by bidder/s the system will activate the 'Freeze Bid Submission' button to conclude the bid submission process.
- (e) **System generated acknowledgement receipt for successful bid submission:** System will generate an acknowledgement receipt for successful bid submission. The bidder/s should make a note of 'Bid ID' generated in the acknowledgement receipt for tracking their bid status.

5.2.5.6 Settlement of Cost of Tender Paper

- (a) **Cost of Tender Paper:** In respect of Government receipts on account of **Cost of Tender Paper**, the e-Procurement portal shall generate a MIS for the State Procurement Cell (SPC). The MIS will contain an abstract of the cost of tender paper collected with reference to **Bid Identification Number**. The State Procurement Cell shall generate Bank-wise-head-wise challans separately for **Cost of Tender Paper** and instruct the designated Banks to remit the money to the State Government account under different heads. In respect of the cost of tender paper received through the e-procurement portal, the remittance to the Cyber Treasury account will be made to the Head of Account 0075-Misc, General Services-800-Other Receipts -0097-Misc. Receipts-02237-Cost of Tender Paper.
- (b) For the time being, the State Procurement Cell (SPC) will use over the counter payment facility of the Odisha Treasury portal. Thereafter, remittance through NEFT & RTGS will be facilitated through the Odisha Treasury portal.
- (c) Similarly, in case of State PSUs, Statutory Corporations, Autonomous Bodies and Local Bodies etc., **(Applicable in case of OSEPA), Cost of Tender Paper**, the e-Procurement portal shall generate a MIS for the State Procurement Cell (SPC). The MIS will contain an abstract of the cost of tender paper collected with reference to **Bid Identification Number**. The State Procurement Cell shall generate Bank-wise list of challans and instruct the designated Banks to remit the money through the Odisha Treasury portal. The cost of tender papers will be credited to the registered Bank account of the concerned State PSUs, Statutory Corporations, Autonomous Bodies and Local Bodies etc.
- (d) Bank will refund (in case the Tender Inviting Authority (OSEPA) issues such instructions) the tender fee, to the bidder/s, in case the tender is cancelled before opening of Bid as per direction received from Tender Inviting Authority (OSEPA) through e-procurement system.
- (e) Back-end Transaction Matrix of Electronic receipt of Cost of Tender Paper on submission of bids is enclosed in the Annexure.

5.2.5.7 Role of the Banks:

- (a) Make necessary provision / customizations at their end to enable the provision for online payments / refunds as per this document.
- (b) Provide necessary real-time message to bidder/s regarding successful or unsuccessful transactions during online payment processes and redirect them to e-Procurement website with necessary transaction reference details enabling them to submit their bids.
- (c) The bank shall ensure transfer of funds from the pooling account to the Government Head/current account of PSUs/ULBs within the next bank working day as per the directions generated from e-Procurement portal.
- (d) Bank should provide timely reports and reference details to NIC enabling them to carry out their role as stated below.
- (e) Refund of amount to bidder/s as per the XML file provided by e-Procurement system on the next bank working day from the date of generation of the XML file and also provide a confirmation to NIC on the same.

5.2.5.8 Role of State Procurement Cell (SPC) :

- (a) Communicate requirements of Government departments/ State PSUs/ Autonomous Bodies/ ULBs online payment requirements to National Informatics Centre / the authorised Banks for mapping/ customization.

- (b) In every working day, the State Procurement Cell shall generate MIS from the e-Procurement portal to ascertain the tender paper cost received in the e-Tendering process separately bank-wise for the Government Department and the PSUs/ULBs. The SPC shall generate bank-wise separate online challans from the Odisha Treasury portal and make the remittance through over the counter facility or NEFT / RTGS (as and when this functionality is available in Treasury portal) and issue instruction to the bank for remittance of the receipt to the State Government account.
- (c) The State Procurement Cell shall be responsible for providing challan details and MIS in respect of the remittance towards tender paper cost to the Tender inviting authorities for their record.
- (d) State Procurement Cell shall monitor the progress of e-Tendering by different Government departments / State PSUs/ Autonomous Bodies / ULBs through an MIS. State Procurement Cell shall monitor and send monthly progress reports to the Government.
- (e) The e-Procurement system will generate a consolidated refund & settlement XML file as an end of the day activity.
- (f) e-procurement system will provide a web service for payment gateway (PG) provider to pull the encrypted refund and settlement details in XML file against a day.
- (g) Similarly, payment gateway (PG) provider will provide a web service to pull the refund and settlement status against a day.
- (h) e-procurement system will update the status accordingly for reconciliation report.

5.2.5.9 Role of National Informatics Centre :

- (a) Customize e-Procurement software and web-pages of Government of Odisha (<https://tendersodisha.gov.in>) to enable the provision for electronic payment.
- (b) The NIC, Odisha will modify / rectify the errors in electronic data relating to the Chart of Account.
- (c) NIC will provide an interface to organisations to download the electronic receipt data.
- (d) Enable automatic generation of daily XML files from e-Procurement system and ensure delivery of the same to the authorised Banks for enabling automatic refund/settlement of funds.
- (e) NIC shall enable the e-Procurement portal to generate MIS as required for the State Procurement Cell in order to make remittance of the tender paper cost to the State Government account using the Odisha Treasury portal.

5.2.5.10 Role of Cyber Treasury :

- (a) The cost of the tender paper deposited by the SPC using the Odisha Treasury Portal which will be accounted for by the Cyber Treasury and it shall submit the accounts to A.G (O) as per the established process.
- (b) The Cyber Treasury will provide MIS as required to the SPC for the purpose of accounting and reconciliation of the electronic remittances made to the State Government account.

5.2.5.11 Redressal of Public grievances :

The State Procurement Cell, Odisha, National Informatics Centre, Odisha and the e-FPB will have an effective procedure for dealing with, public complaint for e-Receipt related matters. In case, any mistake is detected by any of the stakeholders in reporting of receipt of tender paper cost, either suo motu or on being brought to its notice, the State Procurement Cell, Odisha, National Informatics Centre, Odisha unit, Cyber Treasury and the bank will promptly take steps for rectification. The e-Focal Point Branch of the participating Banks, National

Informatics Centre, Odisha and the State Procurement Cell, Odisha will notify the contact number and address of the Help Desk for resolution of any dispute regarding e-Receipt.

5.2.5.12 Applicability and modification of existing rules / orders:

The modalities prescribed in this Office Memorandum for downloading of tender paper, submission and rejection of bid, acceptance of Bids as well as refund and forfeiture of earnest deposit will be applicable for electronic submission of bids through e-procurement portal. Existing provisions regulating cost of tender paper, in OPWD Code and OGFR would stand modified to the extent prescribed.

Back-end Transaction Matrix of Electronic receipt and remittance of Cost of Tender Paper on submission of bids.

Annexure-I

	Cost of Tender paper on submission of Bids
Government Departments	<p>I. The payment towards the cost of Tender Paper, in case Government Departments shall be collected in separate Pooling accounts opened in Focal Point Branch called e-FPB of respective designated banks [as stated in Para 5.2.5.2] at Bhubaneswar on T+1_day.</p> <p>II. With reference to the Notice Inviting Tender / Bid Identification Number, the amount so realised is to be remitted to Government Account under head of Account 0075- Misc. General Services-800-Other Receipts -0097-Misc.Receipts-02237-Cost of Tender paper through Odisha Treasury portal after opening of the bid .</p>
State PSUs, Statutory Corporations, Autonomous Bodies and Local Bodies (Applicable in case of OSEPA)	<p>I. In case of State PSUs, Statutory Corporations, Autonomous Bodies and Local Bodies etc. the amount towards Cost of Tender Paper on submission of bids shall be collected in. separate pooling accounts opened in Focal Point Branch called e-FPB of respective designated banks at Bhubaneswar on T+1 day.</p> <p>II. The Paper cost will be transferred to the respective current accounts of concerned State PSUs, Statutory Corporations, Autonomous Bodies and Local Bodies etc. after opening of Bid</p>

5.3 Exemption/preference for local Micro & Small Enterprise (MSEs) registered with respective DICs, Khadi, Village, Cottage and Handicraft Industries, OSIC & NSIC.

As the TLM on Mathematics are to be procured out of Samagra Shiksha fund, no exemption / preference shall be allowed to any SSI units/local MSEs or any other agencies as per Gol letter dated 22nd August 2012.

5.4 Availability of Sample for Viewing by potential bidder/s.

A sample of TLM on Mathematics shall be made available in Pedagogy Section of OSEPA for viewing by the potential bidder/ss. For details the bidder/s are required to refer the detailed technical specifications given in the BID document.

5.5 Quantity Required:

At present the total quantity required would be around 12746. List of district wise requirement is attached at **Annexure-C**. The quantity may increase / decrease as per need which will be communicated in the Supply order.

5.7 Submission of Samples:

The bidder/s is to submit a sample kit in off-line mode either by post or courier only. No other mode of submission of sample kit is acceptable. Failure to submit the sample kit as tendered on or before the stipulated date of submission will lead to automatic rejection of the bid of concerned bidder/s. **Submission of more than one set of sample will not be accepted & lead to rejection of the bid.**

5.8 Specification and design of Mathematics Learning Kit.

The specification of the Mathematics Learning Kit is provided in the **Section-6** of the BID document.

5.9 Responsibility of the bidder/s to verify the Contents of Bid Document:

5.9.1 The bidder/s shall examine all instructions, forms, terms and specifications contained in the Bid Document and verify that all the contents mentioned in the 'Bid Document'.

5.9.2 Failure to furnish any information as required in the bid document and submission of an offer not substantially responsive to it in every respect shall be at the bidder/s's risk and may result in the rejection of the bids, without any further notice.

5.10 Guidelines for Preparation of Bid:

5.10.1 The Bidder/s shall bear all costs associated with the preparation and submission of its bid and **OSEPA**, as "Tender Inviting Authority" will in no case be responsible or liable for these costs, regardless of the conduct or outcome of the bidding process. The **documents to be submitted** online is mentioned in clause **5.12.1**.

5.10.2 In the event of documentary proof as required being not enclosed/uploaded, the Bid shall be liable for rejection. All pages of the bid shall be signed by the authorized person or persons signing the bid along with the seal/stamp of the bidder/s.

5.10.3 **Language of Bid:-** The Bid prepared by the bidder/s and all correspondence and documents relating to the bid exchanged by the bidder/s and the Tender Inviting Authority, shall be in English/Hindi/Odia language. Supporting documents and printed literature furnished by the bidder/s may be written in another language provided they are accompanied by an authenticated accurate translation of the relevant passages in the English language in which case, for purposes of interpretation of the Bid, the English translation shall govern.

5.10.4 An offer submitted in vague / ambiguous financial terms and the like, shall be termed as non-responsive and shall be summarily rejected.

5.10.5 Clarifications on specific requests, if felt necessary by the Tender Inviting authority, shall be responded through e-mail and general clarifications, affecting all the bidder/s shall be published in the official website of the Tender Inviting Authority (osepa.odisha.gov.in). However, it shall be the duty of the prospective bidder/s to ensure that the clarifications sought for has been properly received in time by the Tender Inviting Authority.

5.10.6 Any clarification on the e-Tender procedure shall be obtained from OSEPA (contract no. 0674-2391217) and State Procurement cell help desk **1800-3456765, 0674-2530998**.

5.11 A **Pre-bid conference** shall be arranged on dated at 11:30 AM of 10/01/2022 in the conference hall of OSEPA for clarifying issues and clearing doubts, if any, to be raised by the potential bidder/s.

5.12 Submission of Bid:

The bids are to be submitted **on-line** in two parts in the e-Tender portal. Each process in the e-procurement is time stamped and the system can detect the time of log in of each user including the Bidder/s. Part-1 as Technical Bid and Part-II as Financial Bid.

5.12.1 Submission of Technical Bid:

The list of documents (scanned documents to be uploaded online in PDF format) as part of Technical Bid are mentioned below:

- (a) Copy of manufacturing license from Appropriate Authority of Government (State Govt. /Central Govt. /UT Govt.) if bidder/s is a manufacturer.
- (b) Copy of GST Registration Certificate.
- (c) Copy of GST Return (GSTR-3B & GSTR-1) filed for the last Tax period in case of GST Registration Certificate issued by the Competent Authority of Odisha. In case of the bidder/s from outside State, copy of GST return of last Tax period and affidavit enclosed at **Annexure-A**.
- (d) Copy of the PAN /TAN
- (e) Copy of the Income Tax Return, Audited Balance Sheet, P/L Account and Trading Account for the year in which the annual turnover is Rs.3.00 crore or more in any one of the last 03 financial years i.e 2018-19,2019-20 & 2020-21
- (f) Documentary proof of work order/contract agreement/supply completion certificate from Govt./Govt aided organization in support of experience in supplying Educational Kits / Math Kits / Science kits / or equivalent Teaching or Learning materials to Govt./Govt aided organization in any one of years from 2018-19 to 2021-22. The minimum size of such a contract should have been for supply of 1000 units of any type of kit/equivalent teaching or learning materials.
- (g) One Sample Mathematics Learning Kit comprising of TLMs no Item.1 to 20 and paper in A4 size used for printing of Teacher's Manual (Item 23) confirming to technical specifications. Submission of samples in English language, wherever Odia is specified, will also be accepted only for technical bid evaluation purpose.
- (h) Test Report of sample Mathematics Learning Kit on Point No.5 (Material) of Item No.1 to 20 of the Technical Specification from any Govt. testing Laboratory (State Govt /Central Govt /UT Govt) **or** from any NABL Accredited Testing laboratory of India.
- (i) Test certificate confirming to IS 9873 (Part 3) or ISO 8124-3 for the materials used in the manufacturing of Mathematics Learning Kits, from any Govt. testing Laboratory (State Govt /Central Govt /UT Govt) **or** from any NABL Accredited Testing laboratory of India.
- (j) Declaration in prescribed format (Annexure-B) in shape of an affidavit before executive Magistrate / Notary Public.
- (k) Check list as in **TECH-3** , properly filled in format **TECH 1 & 2 & Bid security /EMD declaration in Tech-4**.

All above documents should be uploaded / submitted online with seal & signature of the bidder/s.

Note: Any financial information should not be mentioned in the Technical Bid.

5.12.2 Submission of Financial Bid:

- (a) **PART II as FINANCIAL BID** (in the required Format) shall be submitted **online only**. The Financial bid format (excel sheet available in e-Tender portal) is specific to a bid and is not interchangeable. The Financial bid format file shall be downloaded from the e-Tender portal and quote the prices in the respective fields before uploading it. The Financial bid submitted in **any other formats** will be treated as non-responsive. Multiple Financial bid submission by bidder/s shall lead to rejection of bid.
- (b) The blank Financial bid format should be downloaded and saved on bidder/s's computer without changing file-name otherwise price bid will not get uploaded. The bidder/s should fill in the details and upload the same back to the website.
- (c) A bid submitted with an adjustable/variable price quotation will be treated as non - responsive and liable for rejection.

- (d) Prices quoted by the Bidder/s shall be fixed during the period of the contract and not subject to variation on any account.
- (e) Price offered shall be in Indian rupees and there shall also be no hidden costs.
- (f) The price quoted shall be F.O.R. destination **i.e. at respective Districts** which means that prices shall include the cost of delivery at destination. All the transit risk shall be the responsibility of the supplier.
- (g) Bidder/s shall quote prices in all necessary fields in the available format. The price shall be entered separately in the following manner.
 - (i) **Base Price:** Base price is inclusive of all other taxes, charges, levies, duties, cost of packing, transportation up to delivery points etc. except GST as applicable.
 - (ii) GST as applicable is to be quoted separately in the specified field in numeric values and in Indian Rupees. If the field is left blank, value will be taken as Zero and the quoted price will be treated as inclusive GST.
- (h) Bidder/s cannot alter / modify the Financial bid / BOQ format, if so their bid is liable for rejection.
- (i) No bidder/s shall be allowed at any time on any ground, whatsoever it may be to claim revision or modification in the rates quoted by him. Representation to make correction in the tender documents on the ground of Clerical error, typographical error, etc., committed by the bidder/s in the Bids shall not be entertained after final submission of the tender. Conditions such as "SUBJECT TO AVAILABILITY" "SUPPLIES WILL BE MADE AS AND WHEN SUPPLIES ARE RECEIVED" etc., will not be entertained under any circumstances and the tenders of those who have given such conditions shall be treated as incomplete and accordingly the Tenders will be liable for rejection.

5.12.3 The bidder/s should **check** the **system generated confirmation statement** on the status of the submission.

5.12.4 **Signing of Bid:**

The bidder/s shall digitally sign on all statements, documents, certificates uploaded by him, owning responsibility for their correctness / authenticity. If any of the information furnished by the bidder/s is found to be false / fabricated / fake, the EMD/Bid Security shall stand forfeited & his/her name shall be liable for recommending for blocking of portal registration and blacklisting thereof.

5.12.5 **Security of Bid Submission:**

All bid uploaded by the bidder/s to the e-procurement portal will be encrypted. The encrypted bid can only be decrypted / opened by the authorised openers on or after the stipulated date and time.

5.12.6 **Resubmission and withdrawal of Bids:**

Resubmission of bid by the bidder/s for any number of times before the final date and time of submission is allowed. Resubmission of bid shall require uploading of all documents including price bid afresh. If the bidder/s fails to submit his modified bids within the predefined time of receipt, the system shall consider only the last bid submitted.

5.12.7 The Bidder/s can withdraw its bid before the closure date and time of receipt of the bid by uploading scanned copy of a letter addressing to the Procurement Officer-Publisher (Officer Inviting Bid) citing reasons for withdrawal. The system shall not allow any withdrawal after expiry of the closure time of the bid.

5.12.8 The bidder/s should avoid submission of bid at the last moment to avoid the system failure & last minute rush. In such case, the Tender Inviting Authority (OSEPA) is not responsible in any manner.

5.13 Opening of the Technical and Financial Bid.

5.13.1 The technical bid shall be opened in online mode on the scheduled date. The date of opening of financial bid shall be decided by Tender Inviting Authority for that bidder/s who has qualified in technical bid evaluation. The date of opening of the Financial bid shall be informed in advance to the technically qualified bidder/s.

5.13.2 The on-line opening of the technical bid and the financial bid shall be done by the Tender Inviting Authority as per bid schedule. The prospective bidder/s can access to the on-line bid opening by logging in to the e-Tender portal with the registered digital signature. Bidder/s or any of their representatives shall not come to the office of the Tender Inviting Authority for the opening of either technical or financial bids.

5.13.3 In the event of the specified date for opening of bid being declared holiday, the Bid shall be opened at the appointed time on the next working day.

5.13.4 The tenders (also called Bids) not submitted in prescribed format or in the prescribed manner, shall be rejected by the Tender Evaluation Committee at the risk and responsibility of the bidder/s.

5.13.5 All the information/documents as called for in the tender document should be submitted truly, clearly, legibly, transparently, unambiguously and without the use of abbreviations. The decision of Tender Inviting Authority (OSEPA) in this regard is final and binding on all the bidder/ss.

5.13.6 There shall be no over-writing in the tender document and other papers to be uploaded. All the additions, alternations, deletions and cuttings should be initialed with Rubber-Stamp (or Seal) by the same person who signed the tender document failing so, the tender may be rejected.

5.13.7 The bidder/s shall be responsible for properly uploading the relevant documents in the format specified in the e-Tender portal in the specific location and the Tender Inviting Authority shall not be held liable for errors or mistakes done while submitting the on-line bid.

5.14 Evaluation of BID

The Technical Evaluation / Purchase Committee constituted by Tender Inviting Authority / Government shall evaluate the BID as under:

- (i) **Technical Bid:** The technical bid shall be scrutinized by the Technical Evaluation Committee formed for the purpose. "For all items except Item No. 19 (Weighing Balance) tolerance of +/- 5% will be considered. For Item No.19, variants of length, breadth and height will be considered as long as both weight & volume concepts can be taught using it.. The decision of the Technical Committee shall be final and binding on all the bidder/s.
- (ii) **Financial Bid:** The names of the technically qualified bidder/s after evaluation will be declared and uploaded on <https://tendersodisha.gov.in> and osepa.odisha.gov.in & Financial Bid of only the technically qualified bidder/s will be opened.
- (iii) The auto generated comparison list generated through the e-tender portal after financial bid opening is not the **final evaluation list**. Manual evaluation shall be carried out by the tender inviting authority based on the quoted price in the e tender portal, after correction of arithmetic error, if any, prevailing rate of GST etc...and the evaluation criteria mentioned above to arrive at the lowest evaluated responsive bid.

5.15 Award of Contract, Signing of agreement and deposit of performance security

(a) The contract will be awarded to the Bidder/s substantially responsive to the Bid & who has offered the lowest evaluated cost.

(b) The selected bidder/s will have to enter into an agreement with the Tender Inviting Authority i.e. OSEPA. The agreement duly filled in indicating the amount of "Performance Security" and signed by the supplier(s) with the attestation and common seal affixed with special adhesive stamp (Non-Judicial) not less than worth of Rs.10/- (Rupees Ten) only should be submitted within 07 days from the date of issue of supply order. The first page of the Agreement should be written on non-judicial stamp paper of Rs.10/- if stamp paper of Rs.10/- denomination is not available, a no. of small denomination may be used in that place.

(c) The selected bidder/s shall have to submit performance security deposit of 03% of the contract value in shape of Bank Draft / Bank Guarantee (BG) drawn on any Nationalized / scheduled bank in favour of State Project Director, OSEPA along with the agreement. In case of Bank Guarantee, the valid period shall be one year from the date of issue of supply order. The "Performance Security" may be forfeited partly or fully for failure to fulfil the terms and conditions of supply and obligation as mentioned in Contract Agreement. The Bank Guarantee if furnished towards performance security should be enforceable and payable at Bhubaneswar and should be as per **Annexure-D**.

(d) The Authority reserves the right to modify any term in the bid document at the time of execution of agreement, if necessary.

(e) If a special situation arises, where the lowest evaluated responsive bidder/s is not in a position to supply the full quantity required, the remaining quantity, as far as possible, be ordered on the next higher responsive bidder/s(s) at the rate offered by the lowest evaluated responsive bidder/s, after obtaining approval from the competent Authority on the specific recommendation of the respective purchase Committee.

(f) The selected / successful bidder will have to submit two sets of TLM on Mathematics with all items along with printed Odia numerals / letters as required, Kit Contents Sticker, Kit Tracking Sticker and Teachers' Handbook, before getting supply order, as per instruction of the Tender Inviting Authority."

5.16 Acceptance or Rejection of the Bids:

- (a) OSEPA reserves the right to accept / reject any / all bids / cancel the entire selection process at any stage without assigning any reason thereof. No claim, whatsoever, shall be admissible for the alleged loss/damage suffered by the bidder/s on account of such rejections.
- (b) Any bid with incomplete information is liable for rejection.

5.17 Delivery Schedule, collection of samples and distribution :

- (a) The successful bidder/s is to deliver the Mathematics Learning Kits at District points & at State Project Office within 100 days from the date of issue of **supply order**.
- (b) **Collection of Samples after Delivery:** After supply of the Math Kits at district point and before its distribution to Schools, a team from district level comprising members from O/o District Education Officer (DEO) and District Project Coordinator (DPC) shall draw **two samples** per district randomly. The district wise samples drawn are then to be sent to SPO, OSEPA. An Internal Evaluation Committee of OSEPA along with Technical Experts as special invitees will evaluate the sample kits as sent by DPOs. The said Internal Evaluation Committee reserves the right to send some of the

randomly collected samples received from DPO for testing in Government laboratory (State Govt /Central Govt /UT Govt) if so decided. In such case the cost of testing is to be borne by the successful bidder/s & OSEPA on 50:50 ratio.

- (c) The DPC will receive, make necessary stock entry of TLM on Mathematics & distribute them to the BEOs/DIETs/DRCs after observing due procedure. The DIETs/DRCs will keep the TLM on Mathematics received from DPC & maintain record thereof for future reference. The BEOs will distribute the Mathematics Learning Kits to the schools after observing due procedure. The DEO & DPC will supervise, monitor & co-ordinate the distribution of Mathematics Learning Kits, keep records thereof for scrutiny by various Audit/Inspection authorities in future.

5.18 **Extension of Delivery Period , Liquidation Damages, Force Majeure and Penalty:**

The Tender Inviting Authority i.e. OSEPA may, on the request of the Supplier or otherwise, extend the delivery date suitably subject to the following conditions:

- i. The original Delivery Period may be re-fixed by the Tender Inviting Authority (OSEPA) without any Liquidated damages subject to Force Majeure conditions mentioned below and also on the ground/reasons of delay attributable to the Tender Inviting Authority (OSEPA).
- ii. For other cases, the Delivery Period may be suitably extended for which an amount equal to the Liquidated Damages for the extended period(s) for delay in the supply of the Goods after the expiry of contract delivery period /re-fixed delivery period, shall be recovered from the Supplier as mentioned hereinafter for the extended period. Nevertheless the Tender Inviting Authority (TIA) i.e. OSEPA shall be entitled to the benefit of any decrease in price on account of reduction in GST/other taxes, levies or duties if any taking place during extended delivery period.
- iii. **Liquidated Damages:** If the Supplier fails to deliver any or all of the Mathematics Learning Kits within the original/re-fixed delivery period(s) specified in the contract, the Tender Inviting Authority i.e. OSEPA will be entitled to deduct/recover the Liquidated Damages for the delay, unless covered under Force Majeure conditions as mentioned below, @ 0.5% per week or part of the week of delayed period of the value of the quantity supplied after the original/re-fixed delivery period(s) as pre-estimated damages not exceeding 10% of the value of the quantity supplied after the original/re-fixed delivery period(s) without any controversy/dispute of any sort whatsoever.
- iv. **Force Majeure Conditions:**

If at any time during the continuance of the Contract agreement, the performance in whole or in part by either party of any obligation under this Contract shall be prevented or delayed by the reasons of any war, hostility, acts of the public enemy, epidemics, civil commotion, sabotage, fires, floods, explosion, quarantine restrictions, strikes, lockouts or act of God provided notice of happening of such event duly evidenced with documents is given by one party to the other within 10 days from the date of occurrence thereof, neither party shall be by reasons of such event, be entitled to terminate the Contract nor shall either party have any claim for damages against the other in respect of such non-performance or the delay in performance, and deliveries under the contract shall be resumed as soon as practicable after such event has come to an end or ceased to exist, and the decision of the Tender Inviting Authority i.e. OSEPA as to whether the deliveries have been so resumed or not, shall be final and conclusive, Provided further that if the performance in whole or part of any obligation under this contract is prevented or delayed by reason of any such event for a period exceeding **10 days**, either party may at its option terminate the contract provided also that the Tender Inviting Authority i.e. OSEPA shall be at liberty to take over from the Supplier at a price to be fixed by Tender Inviting Authority i.e. OSEPA, which shall be final, all unused, undamaged and accepted material,

bought out components and Goods in course of manufacture in the possession of the Supplier at the time of such termination or such portion thereof as the Tender Inviting Authority i.e. OSEPA may deem fit excepting such materials, bought out components and Goods as the Supplier may with the concurrence of the Tender Inviting Authority i.e. OSEPA elect to retain.

- (v) Overall responsibility of the quality confirming the tendering specification shall rests with successful bidder/s. If the goods supplied are not fully in conformity to the required specification, OSEPA reserves the right to exercise its discretion to impose penalty such as price reduction, forfeit of performance security, initiating of proceedings towards blacklisting of bidder/s etc... which will be binding on the supplier.

5.19 **Payment Terms:**

- (i) **On Delivery at Destination:** 80% of the supplied value basing on supply order shall be paid at State Project Office (SPO) on the basis of District-wise/SPO-wise supply of tendered items, within 30 days after receipt of the required reports / Papers/ documents as under:
 - a. Challans towards satisfactory completion of supply of full quantity to concerned district/SPO as per supply order.
 - b. Receipt of "receive & stock entry certificate" from concerned district/SPO.
 - c. On fulfillment of all other conditions of the agreement.
 - d. Four self-inking carbon copies of the GSTIN invoice and challans duly sealed, signed and countersigned by the receiving Authorities at the District/SPO level as well as bank details for payment purpose.
- (ii) **On Final Acceptance:** 20% of the total contract price shall be paid at State Project Office (SPO), after deduction of penalty, if any, within 30 days of :
 - a. Complete supply of quantity as per supply order.
 - b. Outcome of post-delivery sample Evaluation Report.
 - c. Four self-inking carbon copies of the GSTIN invoice as well as bank details for payment purpose.
- (iii) (a) No advance payment shall be made, or no payment shall be entertained on negotiation through Bank.
 - (b) Deduction of tax at source shall be made at the appropriate rate as per prevailing law.
 - (c) OSEPA reserves the right towards release of payment after obtaining approval of appropriate Authority.

5.20 **Bid validity period.**

The BID shall remain valid for a period of **90 (Ninety Days)** from the date of opening of the Financial Bid. The OSEPA reserves the rights to reject a proposal valid for a shorter period as non-responsive and will make the best efforts to finalize the selection process and award of the contract within the bid validity period. The bid validity period may be extended on mutual consent.

5.21 **Amendments to BID terms ,conditions and issue of Corrigendum/addendum:**

- (i) Seven days before the last date of submission of Bids, OSEPA may, for any reason, whether at its own initiative or in response to a clarification requested by a prospective Bidder/s, modify the Bidding Documents by amendment/corrigendum.
- (ii) The amendment in shape of corrigendum/addendum will be notified on the websites <https://tendersodisha.gov.in> and osepa.odisha.gov.in and the prospective bidder/s are requested to take cognizance of such notification/s while submitting their tender proposal.
- (iii) In order to allow prospective Bidder/s reasonable time in which to take the amendment into account in preparing their bid, OSEPA may, at its discretion, extend the deadline for the submission of bids.

- 5.22 “Legal Status” of a bidder/s shall mean either proprietorship or partnership or private / public limited company or otherwise (to be specified), as the case may be.
- 5.23 Submission of more than one competitive bid by the same firm in response to the tender call notice is prohibited. In such case, the bids will not be considered.
- 5.24 The bidder/s may use separate piece of paper, where the space provided in the formats in this tender document for submission of information, is not sufficient. The information in the separate sheet of paper shall be in prescribed format and its page should be serially numbered and duly authenticated while uploading.
- 5.25 All the information uploaded & submitted or supplied in the formats of this tender document shall be presumed to be true to the best of the knowledge of the bidder/s.
- 5.26 No document as required and mentioned in the Bid shall be uploaded to the Technical bid / Financial bid documents unless otherwise specifically mentioned therein. All required documents shall be uploaded with serial number and page mark.
- 5.27 Entire tender document, duly filled in, shall be treated as part of the contract agreement for supplies in case of the successful bidder/s and shall be submitted in original.
- 5.28 The samples of bidder/s (both successful & unsuccessful bidder/s) shall not be returned.
- 5.29 The Authority reserves the right to modify any term in the bid document at the time of execution of contract, if felt necessary.
- 5.30 The bidder/s shall upload all required documents along with tender. No documents/papers will be received in offline mode by the Tender Initiating Authority (OSEPA).
- 5.31 Any objection / suggestion / complaint by any bidder/s with regard to tender shall be intimated in writing in respective letter head to the tender inviting authority. The Chairman / Members of Technical / Purchase Committee would not entertain any correspondence / discussion in the above matter.
- 5.32 **Resolution of Disputes:**
- (a) Any dispute between the Tender Inviting Authority (OSEPA) and the successful bidder/s should be addressed to the other party only in writing in their respective letter heads signed only by the designated signatories as in contract agreement. Both the parties shall make every effort to resolve the same amicably by mutual consultations.
- (b) If both the parties fail to resolve their dispute or difference by such mutual consultation within twenty-one days of its occurrence, the same will be referred to by either party for conciliation to the conciliation panel. For that purpose, both the parties, shall nominate each one member, and both the nominated members shall form the Conciliation panel. In case the panel members report failure of conciliation, the matter shall be referred to arbitration, by the Arbitrator, to be nominated by the Vice Chairperson (VC) OSEPA. The VC OSEPA shall nominate an Arbitrator, whenever required or when a request is made by the successful bidder/s, after the failure of conciliation, to nominate an Arbitrator. The arbitration proceeding shall be as per the provisions of the Arbitration and Conciliation Act 1996 of India.
- 5.33 **Applicable Law and Jurisdiction of Courts:**
- (a) The Contract shall be governed by and interpreted in accordance with the existing law of India in force.
- (b) All disputes relating to the contract is subject to the pecuniary jurisdiction of the Court at Bhubaneswar.
- (c) Prior notice shall be given to OSEPA in writing in their respective letter heads signed only by the designated signatories as in contract agreement all proceedings related to the Contract. Arbitration shall be invoked as a pre-condition before approaching courts and tribunals.

Section - 6

Technical Specifications

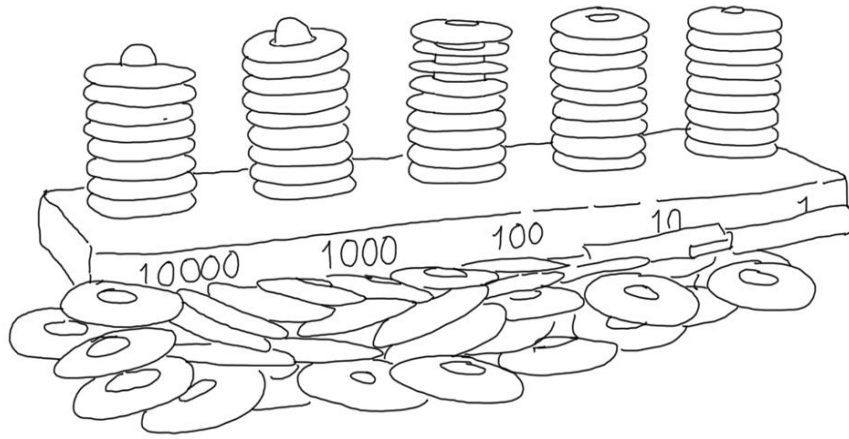

1. Serial No.	Item - 1
2. Title of the Item	Abacus (Board, Rings & Rods)
3. Description of the Item	5 Rod Abacus that holds up to 9 rings and with additional black extension rods to hold another 10 rings. The rods & rings are in 5 colors, yellow for ones (୧), blue for tens (୧୦), green for hundreds (୧୦୦), red for thousands (୧୦୦୦) and white for ten thousands (୧୦୦୦୦).
4. Size	<ul style="list-style-type: none"> a. Base - 250 mm length X 75 mm width X 15 mm thickness b. Rings – 30 mm outer dia X 10 mm hole dia X 5 mm thickness c. Rods - 45 mm length X 9.5 mm dia
5. Material	<ul style="list-style-type: none"> a. Base – Wooden b. Rings – equivalent of Polypropylene (PP) or higher / equivalent of HDPE or higher, that serves the utility of that particular Item as per Point 3 “Description of Item”. c. Rods – equivalent of Polypropylene (PP) or higher / equivalent of HDPE or higher, that serves the utility of that particular Item as per Point 3 “Description of Item”.
6. Colour	<ul style="list-style-type: none"> a. Base - Natural b. Rings – Red, Green, Blue, Yellow, White c. Rods - Red, Green, Blue, Yellow, White & Black (extension rods)
7. Print	On the base printing is done in black color, in Odia to show the place value as ୧, ୧୦, ୧୦୦, ୧୦୦୦, ୧୦୦୦୦
8. Finish	Fine and durable printing

9. Quantity	1 set consists of <ul style="list-style-type: none">• Abacus Base with printing and 5 Rods Riveted• Rings – Red, Green, Blue, Yellow – 20 no.s in each color and 10 no.s in white• Rods – Extension Rods in Black color - 2 no.s
10. Package	Rings and Rods are packed in Ziploc cover made of transparent plastics with thickness more than 50 microns

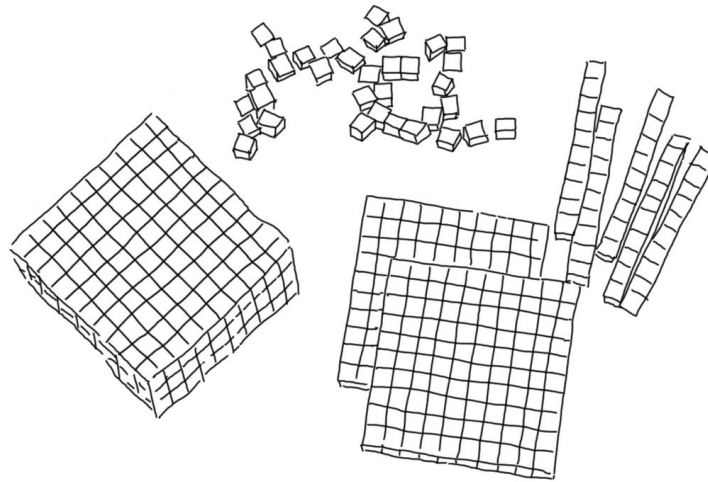

1. Serial No.	Item - 2
2. Title of the Item	Base Ten Blocks
3. Description of the Item	Base ten blocks include <ol style="list-style-type: none"> 1. Unit cubes 2. Tens rods 3. Hundreds plates 4. Thousands cube
4. Size	<ol style="list-style-type: none"> a. Unit cube - 10 X 10 X 10 mm (weight 1 gm) b. Tens rod - 10 X 10 X 100 mm (weight 10 gm) c. Hundreds flats – 100 X 100 X 10 mm d. Thousands cube – 100 X 100 X 100 mm
5. Material	All items molded using equivalent of High Impact Polystyrene(HIPS) or higher/ equivalent of Acrylo Butadene Styrene(ABS) or higher, that serves the utility of that particular Item as per Point 3 of “Description of Item”.
6. Colour	<ol style="list-style-type: none"> a. Unit cube - Yellow b. Tens rod - Blue c. Hundreds plates – Green d. Thousands cube – Red
7. Print	N/A
8. Finish	Fine

9. Quantity	<ul style="list-style-type: none"> a. Unit cube - 100 nos. b. Tens rod - 20 nos. c. Hundreds plates – 20 nos. d. Thousands cube – 1 no.
10. Package	<ul style="list-style-type: none"> a. Unit Cubes Packed in Ziploc Cover b. Tens rods Packed in Ziploc Cover c. Hundreds Flats & Thousands Cube In carry box d. All Ziploc Covers should be made of transparent plastics with thickness more than 50 microns

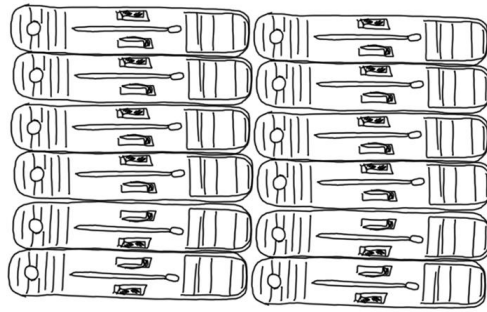

1. Serial No.	Item - 3
2. Title of the Item	Cloth Pins
3. Description of the Item	Plastic clips to be used along with Number Beads.
4. Size	N/A
5. Material	Equivalent of Polypropylene (PP) or higher / equivalent of HDPE or higher, that serves the utility of that particular Item as per Point 3 "Description of Item".
6. Colour	Multi-colour
7. Print	N/A
8. Finish	To be without burr or flash
9. Quantity	12 Nos.
10. Package	Packed in Ziploc cover made of transparent plastics with thickness more than 50 microns

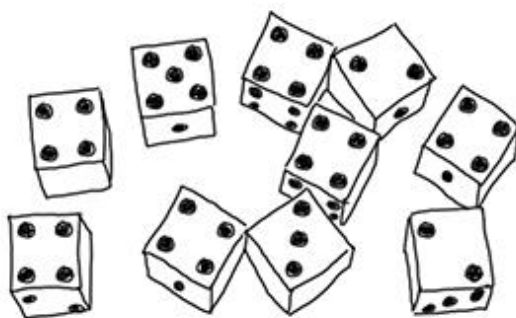

1. Serial No.	Item - 4
2. Title of the Item	Dice
3. Description of the Item	5 pairs of colored dice.
4. Size	Dice cube - 15 x 15 X 15 mm
5. Material	All items molded using equivalent of High Impact Polystyrene(HIPS) or higher/ equivalent of Acrylo Butadene Styrene(ABS) or higher, that serves the utility of that particular Item as per Point 3 of "Description of Item".
6. Colour	White, Red, Green, Blue, Yellow
7. Print	1 No. each of Red, Green, Blue, Yellow & White printed 3 sides – 4 dots insert molded and 3 other sides left blank 1 No. each of Red, Green, Blue, Yellow & White printed 5 sides – 1 to 5 dots insert molded and 1 side left blank
8. Finish	Fine finish , rounded edges
9. Quantity	10 Nos. - 2 Nos. each of Red, Green, Blue, Yellow & White color
10. Package	Transparent Plastic Box

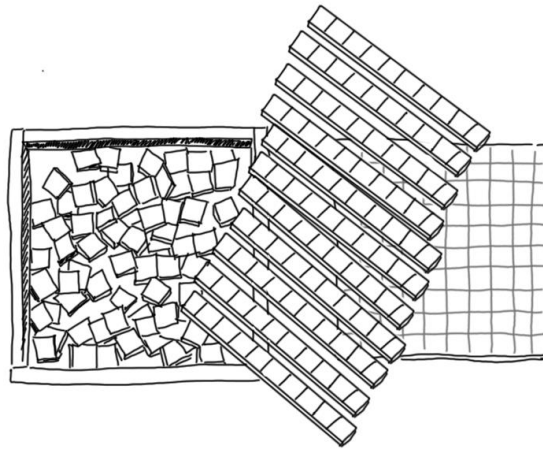

1. Serial No.	Item - 5
2. Title of the Item	Decimal Set with Tray
3. Description of the Item	The yellow big square represents a whole, the rectangle strips in one tenth of the big yellow square and the smaller yellow squares are one tenth of the yellow strips. Tray is provided for easy display & teaching.
4. Size	<ol style="list-style-type: none"> Whole square – 180 x 180 mm Rectangle Strips – 18 x 180 mm Small Square – 18 x 18 mm Tray – 185 x 185 mm
5. Material	EVA Foam – Ethylene Vinyl Acetate, Tray - MDF
6. Color	<ol style="list-style-type: none"> Whole square (Yellow Color) Rectangle Strips (Yellow Color) Small Square (Yellow Color) Tray with frame – Natural Color
7. Print	N/A
8. Finish	Fine
9. Quantity	<p>1 set consists of</p> <ul style="list-style-type: none"> • Full Square – 1 No. • Rectangle Strips – 10 Nos. • Small Square – 100 Nos. • Tray - 1 No.
10. Package	Packed in Ziploc Cover made of transparent plastics with thickness more than 50 microns

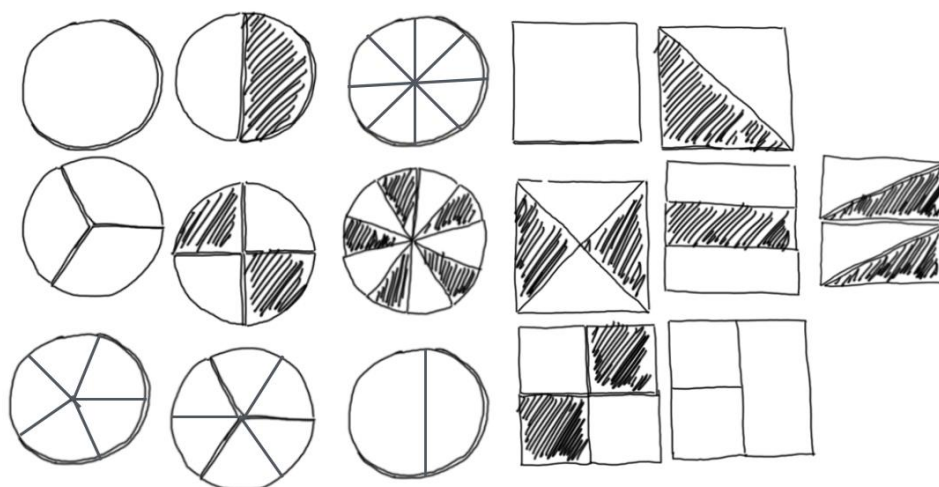

1. Serial No.	Item - 6
2. Title of the Item	Fraction Shapes
3. Description of the Item	The set consists of Circles and Squares and their fractional counterparts.
4. Size	Circle – 120 mm diameter, Square 120 X 120 mm, Rectangle 120 X 40 mm , Right Angle Triangle with Base & Height-120mm x 120mm;
5. Material	EVA Foam – Ethylene Vinyl Acetate.
6. Color	Red, Green, Blue, Yellow, Orange & White;
7. Print	N/A
8. Finish	Smooth
9. Quantity	1 set consists of <ul style="list-style-type: none"> • Full Circle- 1 set of Unequal Parts with 60:40 area ratio • Full circle - 1 no, Half circle – 2 no.s, One third – 3 no.s, One fourth – 4 no.s, One Fifth- 5 no.s, One Sixth- 6 no.s, One eighth- 8 no.s, One tenth – 10 no.s • Full square - 1 no, Half square – 2 no.s, One third – 3 no.s, One fourth – 4 nos. • Half triangle – 2 nos. , One fourth triangle – 4 no.s
10. Package	Packed in Ziploc Cover made of transparent plastics with thickness more than 50 microns

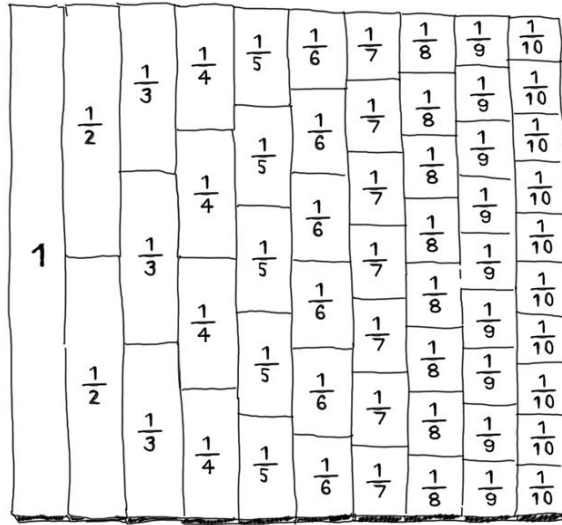

1. Serial No.	Item - 7
2. Title of the Item	Fraction Strips
3. Description of the Item	Fraction strips consists of colored, proportionally sized fraction pieces that represent 1, 1/2, 1/3, 1/4, 1/5, 1/6, 1/7, 1/8, 1/9 and 1/10 to be printed in Odia language only (୧, ୧/୨, ୧/୩, ୧/୪, ୧/୫, ୧/୬, ୧/୭, ୧/୮, ୧/୯ and ୧/୧୦)
4. Size	380 X 35 mm – 1 190 X 35 mm – 2 127 X 35 mm – 3 95 X 35 mm – 4 76 X 35 mm – 5 63 X 35 mm - 6 54 X 35 mm - 7 48 X 35 mm - 8 42 X 35 mm - 9 38 X 35 mm - 10
5. Material	EVA Foam – Ethylene Vinyl Acetate
6. Colour	Multicolored
7. Print	Fraction numbers printed in black colour in Odia language only- ୧, ୧/୨, ୧/୩, ୧/୪, ୧/୫, ୧/୬, ୧/୭, ୧/୮, ୧/୯, ୧/୧୦
8. Finish	Smooth with durable printing
9. Quantity	1 set consists of 55 pieces
10. Package	Packed in Ziploc Cover made of transparent plastics with thickness more than 50 microns

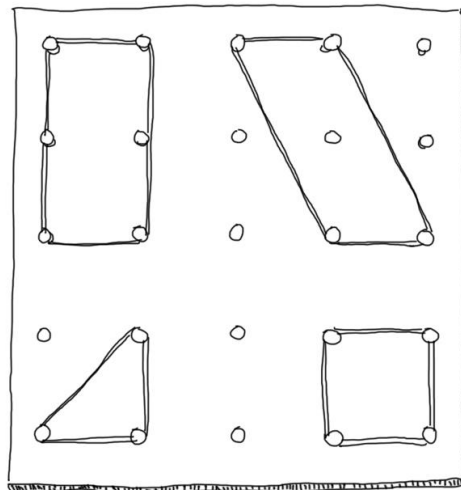

1. Serial No.	Item - 8
2. Title of the Item	Geoboard
3. Description of the Item	Double sided Wooden Geoboard 200 mm square. One side of it will have the pegs arranged as shown and another side to have the pegs arranged in a circle. Pegs should be permanently fixed to the base.
4. Size	<ol style="list-style-type: none"> Base - 200mm square Pegs - 9 mm long X 6 mm diameter Rubber bands - Not less than 4 inch in length
5. Material	<ol style="list-style-type: none"> Base - Wooden Pegs – Equivalent of Polypropylene (PP) or higher / equivalent of HDPE or higher, that serves the utility of that particular Item as per Point 3 “Description of Item”.(insert molded with m.s.pins) Rubber Bands – Rubber
6. Colour	<ol style="list-style-type: none"> Natural Base Yellow Pegs Multicolored Bands
7. Print	N/A
8. Finish	Smooth
9. Quantity	<p>1 set consists of</p> <ul style="list-style-type: none"> • Geoboard – complete 1 no. • Rubber bands – 6 nos.
10. Package	Packed in Ziploc cover made of transparent plastics with thickness more than 50 microns.

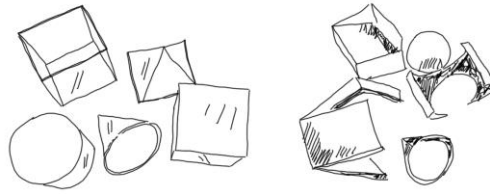

1. Serial No.	Item - 9
2. Title of the Item	Geosolids with Nets
3. Description of the Item	Geosolids , hollow geometric shapes made of transparent plastic along with fold out nets of made of laminated paper with neat markings along creases.
4. Size	<p>Geosolids -</p> <ol style="list-style-type: none"> Cube 62 X 62 X 62 ,mm , Cuboid 82 X 52 X 64 mm Cylinder 64 mm Dia , 64 mm height , Cone 64 mm X 64 mm , Square Pyramid 64 X 64 X 64 mm Lids for above Nets for the above
5. Material	<ol style="list-style-type: none"> Geosolids – Styrene Acrylo Nitrile(SAN) Cover - Styrene Acrylo Nitrile(SAN) Nets - Laminated Paper (220 GSM)
6. Colour	<ol style="list-style-type: none"> Cube – Red, Cuboid – Blue, Cylinder – Red, Cone – Yellow, Square Pyramid – Yellow (all are transparent) Lids - Colorless (Transparent) Nets – White
7. Print	N/A
8. Finish	Smooth
9. Quantity	<p>1 set consists of</p> <ul style="list-style-type: none"> 5 Nos. Geosolids 10 Nos. of Paper Nets
10. Package	Packed in Ziploc cover made of transparent plastics with thickness more than 50 microns

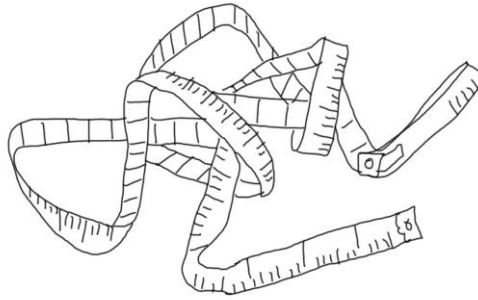

1. Serial No.	Item - 10
2. Title of the Item	Measuring Tape
3. Description of the Item	Measuring tape with calibration in inches and millimeters.
4. Size	1.5 meters / 60 inches
5. Material	Plastic
6. Colour	Multi colors
7. Print	Black color
8. Finish	Smooth
9. Quantity	1 No
10. Package	Inside Carry Box



1. Serial No.	Item - 11
2. Title of the Item	Number Beads
3. Description of the Item	A String of one hundred beads that alternate between red and white colours in groups of ten.
4. Size	Beads -13 mm length X 6 mm hole X 13 mm outer dia String - Approximately 2 meters.
5. Material	Equivalent of Polypropylene (PP) or higher / equivalent of HDPE or higher, that serves the utility of that particular Item as per Point 3 "Description of Item".
6. Colour	White and Red
7. Print	N/A
8. Finish	Smooth Rope ends knotted securely
9. Quantity	1 set consists of 50 Nos white beads & 50 Nos Red Beads on rope
10. Package	Packed in Ziploc cover made of transparent plastics with thickness more than 50 microns

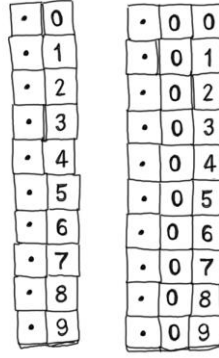

1. Serial No.	Item - 12
2. Title of the Item	Place Value Decimal Strips
3. Description of the Item	Place value decimal strips with decimal numbers printed in Odia language only.
4. Size	70 mm X 35 mm 1 set of (10) 105 mm X 35 mm 1 set of (10)
5. Material	EVA Foam
6. Colour	Grey colour
7. Print	Decimal numbers printed in black colour in Odia language only
8. Finish	Smooth and durable printing
9. Quantity	1 set consists of 10 pcs (.0 to .9) in Odia: .୦, .୧, .୨, .୩, .୪, .୫, .୬, .୭, .୮, .୯, .୧୦ 10 pcs (.00 to .09) in Odia: .୦୦, .୦୧, .୦୨, .୦୩, .୦୪, .୦୫, .୦୬, .୦୭, .୦୮, .୦୯
10. Package	Packed in Ziploc Cover made of transparent plastics with thickness more than 50 microns

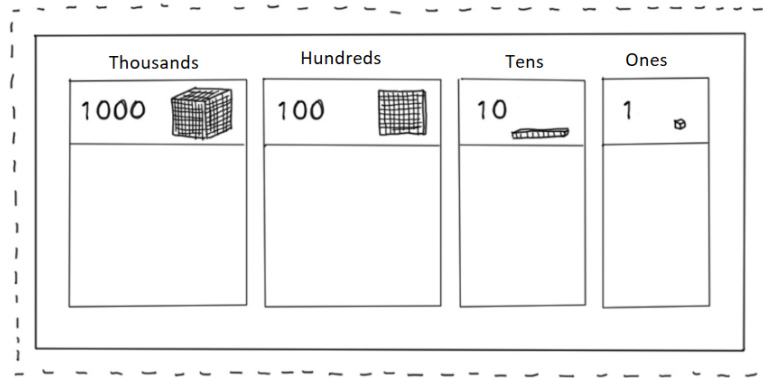

1. Serial No.	Item - 13
2. Title of the Item	Place Value Mat
3. Description of the Item	Place Value Mat - ones, tens, hundreds and thousands. The words-ones, tens, hundreds & thousands have to be printed in Odia only (ଏକକ, ଦଶକ, ଶତକ, ହଜାର). The numbers 1, 10, 100, 1000 have to be printed in Odia only (୧, ୧୦, ୧୦୦, ୧୦୦୦) The pictures in these places should be in color and corresponding Base Ten Blocks as in Item 2 of this document.
4. Size	Sheet size 39 inches X 17 inches Printing size 36.5 inches x 15 inches
5. Material	Mat- Flex Print
6. Colour	Mat- White
7. Print	Printing in Multi colour
8. Finish	Smooth and Durable printing
9. Quantity	1 No.
10. Package	In carry Box

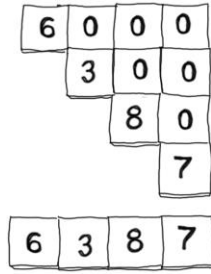

1. Serial No.	Item - 14
2. Title of the Item	Place Value Strips
3. Description of the Item	Colour coded strips to represent place value of numbers namely units, tens, hundreds and thousands. All numbers 1,2,3,4,5,6,7,8,9 and 0 should be printed in Odia only (୧, ୨, ୩, ୪, ୫, ୬, ୭, ୮, ୯ and ୦)
4. Size	Units - 35 X 35 mm Tens - 70 mm X 35 mm Hundreds - 105 mm X 35 mm Thousands - 140 mm X 35 mm
5. Material	EVA Foam
6. Colour	Red, Green, Blue, Yellow,
7. Print	Numbers printed in black colour in Odia
8. Finish	Smooth and Durable printing
9. Quantity	1 set consists of <ul style="list-style-type: none"> • Yellow - 10 pcs. (୦, ୧, ୨, ୩, ୪, ୫, ୬, ୭, ୮, ୯) • Blue - 10 pcs. (୦୦, ୧୦, ୨୦, ୩୦, ୪୦, ୫୦, ୬୦, ୭୦, ୮୦, ୯୦) • Green - 10 pcs. (୦୦୦, ୧୦୦, ୨୦୦, ୩୦୦, ୪୦୦, ୫୦୦, ୬୦୦, ୭୦୦, ୮୦୦, ୯୦୦) • Red - 10 pcs. (୦୦୦୦, ୧୦୦୦, ୨୦୦୦, ୩୦୦୦, ୪୦୦୦, ୫୦୦୦, ୬୦୦୦, ୭୦୦୦, ୮୦୦୦, ୯୦୦୦)
10. Package	Packed in Ziploc Cover made of transparent plastics with thickness more than 50 microns

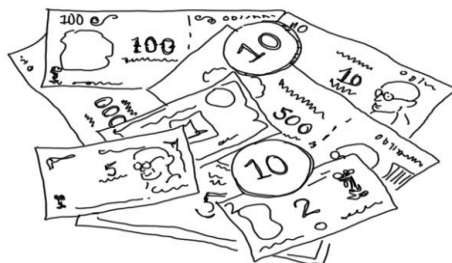

1. Serial No. of the	Item - 15
2. Title of the Item	Play Money and Coins
3. Description of the Item	Rupees of different denominations printed and laminated and coins made of plastic.
4. Size	<p>a. Rupee Note</p> <p>1 Rupee - 60 mm x 35 mm</p> <p>10 Rupee - 75 mm x 37mm</p> <p>100 Rupee - 95 mm x 45 mm</p> <p>1000 Rupee - 105 mm x 45 mm</p> <p>2 Rupee - 60 mm x 35 mm</p> <p>5 Rupee - 60 mm x 35 mm</p> <p>50 Rupee - 95 mm x 45 mm</p> <p>200 Rupee - 100 mm x 45 mm</p> <p>500 Rupee - 105 mm x 45 mm</p> <p>2000 Rupee - 130 mm x 50 mm</p> <p>b. Coins</p> <p>1 paise - 25 mm square</p> <p>10 paise - 31 mm dia</p>
5. Material	<p>a. Rupees Note – 120-130 GSM Paper with lamination</p> <p>b. Coins - Acrylo Butadene Styrene</p>
6. Colour	<p>a. Rupee Notes - Multi colour</p> <p>b. Coins - Grey Colour</p>
7. Print	Replicate Rupee notes with “Play Money” printed on all the notes and according to current design of notes in circulation and according to last used design for notes out of circulation
8. Finish	Smooth
9. Quantity	<p>1 set consists of</p> <ul style="list-style-type: none"> • Rupees 1, 10,100,1000 – 150 Nos. in each denomination • Rupees 2, 5, 50, 200, 500, 2000 – 30 Nos. in each denomination
10. Package	Packed in Ziploc covers made of transparent plastics with thickness more than 50 microns

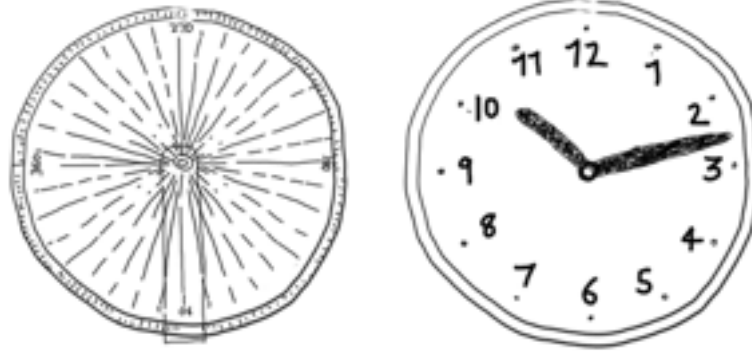

1. Serial No.	Item - 16
2. Title of the Item	Protractor & Clock
3. Description of the Item	<p>Clock – Analogue clock in wood showing 24 hour.</p> <p>Protractor – A full circle protractor with a 0-360 degree scale. Measurements are printed every 10 degrees and only markings for every single-degree in between them.</p>
4. Size	Clock / Protractor Base - 9.5 inches square
5. Material	<ul style="list-style-type: none"> a. Base - Laminated MDF b. Clock Hands – Glass Filled Nylon c. Angle Measure Device – Acrylic Natural d. Hardware – S.S & M.S plated
6. Colour	<ul style="list-style-type: none"> a. Base - Cream/White b. Clock Hands – Black c. Angle Measure Device – Natural
7. Print	Black Colour Print Back to Back Printing
8. Finish	Smooth and durable printing
9. Quantity	1 No.
10. Package	Packed in plastic cover made of transparent plastics with thickness more than 50 microns

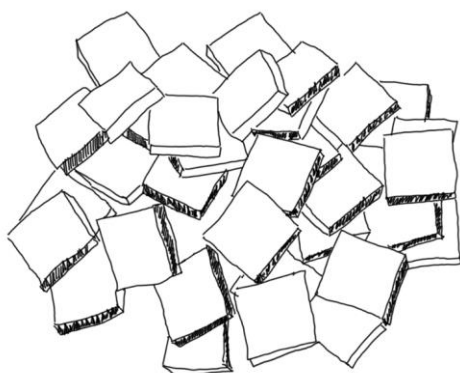

1. Serial No.	Item - 17
2. Title of the Item	Square Counters
3. Description of the Item	1" Squares in five different colour
4. Size	1" Square
5. Material	EVA Foam
6. Colour	Red, Green, Blue, Yellow, Orange
7. Print	N/A
8. Finish	Smooth
9. Quantity	1 set consists of 50 Nos. (10 Nos. each in Red, Green, Blue, Yellow, Orange)
10. Package	Packed in Ziploc Cover made of transparent plastics with thickness more than 50 microns

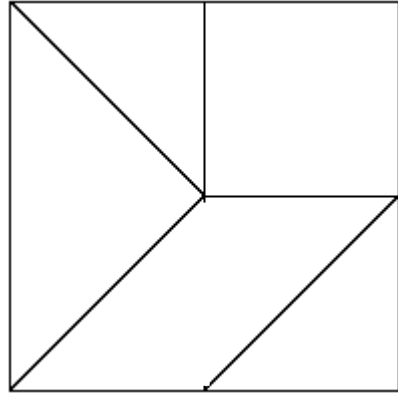
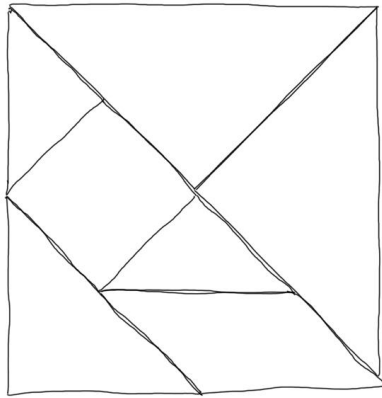

1. Serial No.	Item - 18
2. Title of the Item	Tangram
3. Description of the Item	4 sets of Tangram shapes, 2 of each type- 5 piece Tangram & 7 piece Tangram
4. Size	9 cm square , 5 mm thickness (minimum)
5. Material	EVA Foam – Ethylene Vinyl Acetate
6. Colour	Multicolour
7. Print	N/A
8. Finish	Smooth
9. Quantity	2 sets (7 pieces) & 2 Sets (5 Pieces).
10. Package	Each Set to be packed in Ziploc Cover made of transparent plastics with thickness more than 50 microns

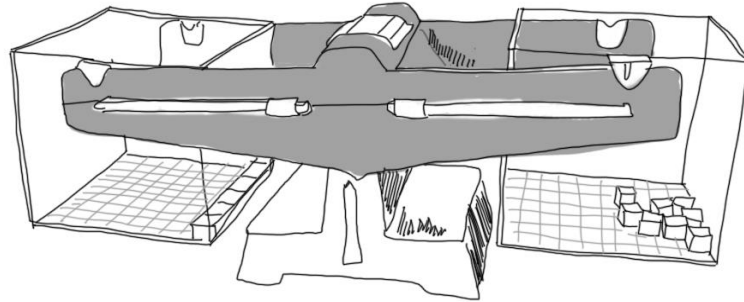

1. Serial No. of the	Item - 19
2. Title of the Item	Weighing Balance with Volume Measure
3. Description of the Item	The weighing balance made of plastic with 2 one liter volume measures, marked in milliliters are removable and made of clear plastic to see what is being weighed. This item will facilitate teaching of both volume and weight concepts.
4. Size	Length 360 mm X width 110 mm X Height 135 mm Note: As long as the item meets the Description and enables teaching of both weight & volume, size variants of Length/Width/Height will be accepted.
5. Material	Balance Body, Stand, Cap, Zero adjuster are moulded using Acrylo Butadene Styrene– Green Volume Measure – Styrene Acrylo Nitrile
6. Colour	Balance Body – Green, Stand - Blue, Cap - Yellow Zero adjuster – Green Volume Measure – Natural
7. Print	Screen Printing done on side of the Volume Measure
8. Finish	Smooth with durable printing
9. Quantity	1 No.
10. Package	Carton Box - Length 360 mm X Width 140 mm X Height 140 mm, or as per size of item submitted.



1. Serial No.	Item - 20
2. Title of the Item	Carry Box
3. Description of the Item	Carry Box made of extruded high strength polypropylene material strong enough to carry the Math Kit items. Two handles given on the sides for ease.
4. Size	14.75 x 12 x 9 inches with provision for locking and Velcro Sticker- 1 inch wide
5. Material	Extruded sheet of Equivalent of Polypropylene (PP) or higher / equivalent of HDPE or higher, that serves the utility of that particular Item as per Point 3 "Description of Item".
6. Colour	White/Yellow
7. Print	N/A
8. Finish	Rigid and smooth
9. Quantity	1 No.
10. Package	Math Kit items are packed in this box

Sl.No	Math Kit Items	Quantity	Picture
1	Square Counter (50)	1 set	
2	Number Line (100 beads)	1 set	
3	Cloth Clips (12)	1 set	
4	Abacus (1), Snap-on Rods (2) & Rings (90)	1 set	
5	Base 10 Blocks (100 Yellow,20 Blue,20 Green,1 Red)	1 set	
6	Place Value Mat	1 no.	
7	Place Value Strips (Yellow,Blue,Green,Red) 10 of each	1 set	
8	Fraction Shapes (42 pieces)	1 set	
9	Fraction Strips (55 pieces)	1 set	
10	Decimal Set (100 of 1/100, 10 of 1/10, 1 Full Square & Board)	1 set	
11	Place Value Decimal Strips (20 pieces)	1 set	
12	Dice (Red, Blue, Green, Yellow,White) 2 of each	1 set	
13	Measuring Tape	1 no.	

1. Serial No.	Item - 21
2. Title of the Item	Kit Contents Sticker
3. Description of the Item	Will list all contents of the kit, including names of items, quantity of each type and sample picture of each item as provided in the kit. All text in this sticker have to be in local language. Header and Footer will contain logos as required.
4. Size	7.5 inches x 10 inches
5. Material	Sticker Paper
6. Colour	White background with colour printing.
7. Print	Color Printing
8. Finish	Matte finish
9. Quantity	1 sticker
10. Package	Will be pasted, centre-aligned, on the inner side of the cover.

DISTRICT- BLOCK- XXXX

Name of Cluster: _____

Name of School: _____

1. Serial No.	Item - 22
2. Title of the Item	Kit Tracking Sticker
3. Description of the Item	Will include a series to reflect the District & Block Code where the kit has been dispatched to as well as include space for writing the name of the school it finally reaches.
4. Size	1.5 inches x 3 inches
5. Material	Sticker Paper
6. Colour	White background with black colour printing.
7. Print	Black Color Printing
8. Finish	Matte finish
9. Quantity	1 sticker
10. Package	Will be put on the outer side of the Carry Box cover.

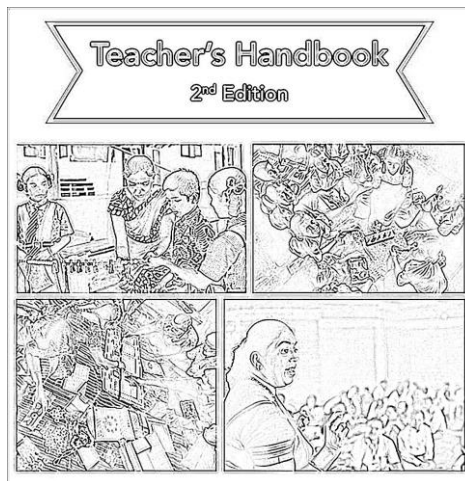

1. Serial No.	Item - 23
2. Title of the Item	Teachers' Handbook
3. Description of the Item	A guideline book on usage of the TLMs in the kit. It has one art board sheet to demonstrate the symmetrical shapes. All text in this book has to be in local language. Print ready material in local language will be made available. Teacher,s handbook will have around 80 pages.
4. Size	8 inches x 11 inches
5. Material	<ul style="list-style-type: none"> • Cover page- 220 GSM, gloss board with gloss lamination. • Inside Paper – 80 GSM Maplitho Paper. • Die-punch - 1 page - 220 GSM, Art Board
6. Colour	As provided in print ready material
7. Print	Color Printing
8. Finish	Gloss Lamination of Cover page with perfect binding
9. Quantity	1 No.
10. Package	Packed in Ziploc Cover made of transparent plastics with thickness more than 50 microns

Section - 7

Technical Bid Formats (Tech-1,2,3,4)

APPLICATION- TECHNICAL BID
For Supply of Teaching Learning Material on Mathematics Learning Kit

COVERING LETTER

(ON BIDDER/S'S LETTER HEAD)

[Location, Date]

To:

**The State Project Director
Odisha School Education Programme Authority
Shiksha Soudha", Unit-V, Bhubaneswar-751001.**

Subject: Supply of Teaching Learning Material on Mathematics.

Dear Sir

I/We, the undersigned, request you to participate in the selection process towards Procurement of TLM on Mathematics in accordance with your Tender Call Notice No _____ dated _____. I/We are hereby submitting our proposal, which includes Technical Bid and Financial Bid separately..

I/We, hereby declare that all the information and statements made in this Technical BID are true and correct and I accept that any misinterpretation contained in it may lead to disqualification of our Bid. Our Bid will be valid for acceptance up to **90 Days** from the date of opening of the financial BID and I confirm that this proposal will remain binding upon us and may be accepted by you at any time before this expiry date.

I/We, hereby unconditionally undertake to accept all the terms and conditions as stipulated in the BID document. In case any provisions of this BID document are found violated, then OSEPA shall without prejudice to any other right or remedy be at liberty to reject our Bid including legal action as per law.

I/We remain,

Yours faithfully,

Place:

BIDDER/S'S OFFICIAL SIGNATORY

Date:

Name & Designation with Rubber Stamp

Bidder/s's Organisation (General Details)

SI No.	Description	Full Details
1	Name of the Bidder/s	
2	Address for Communication Tel : Fax: Email id :	
3	Name of the authorized person signing & submitting the bid on behalf of the Bidder/s: Mobile No. : Email id :	
4	Registration / Incorporation Details Registration No: Date & Year. :	
5	Local office in Odisha If Yes, Please furnish contact details	Yes / No
6	Cost of Tender paper Details Amount :Rs.5,000/- (to be submitted in on-line mode)	
7	GSTIN	
8	PAN / TAN Number	
9	Confirm to carry out assignments as per the scope of work of the Bid Document	YES
10	Confirm to accept all the terms and conditions as specified in the Bid Document	YES

Place:

BIDDER/S'S OFFICIAL SIGNATORY

Date:

Name & Designation with Rubber Stamp

Check list of documents & Items to be enclosed with Technical Bid

Sl. No	Nature and Type of Document/Items	Whether enclosed (with page reference)	
		Yes / No	Page Reference
1	Copy of manufacturing license from appropriate Authority of Government(State Govt./Central Govt./UT Govt.) in case of bidder/s is a manufacturer		
2	Valid Registration certificate issued under GST Act		
3	Copy of GST Return (GSTR-3B & GSTR-1) filed for the last Tax period in case of GST Registration Certificate issued by the Competent Authority of Odisha. In case of the bidder/s from outside State, copy of GST return of last Tax period.		
4	Affidavit in prescribed format by the supplier of outside Odisha declaring that they have no business in Odisha nor they have any OGST liabilities (Annexure-A)		
5	Copy of the PAN/TAN		
6	Copy of the Income Tax Return, Audited Balance Sheet, P/L Account and Trading Account for the year in which the annual turnover is Rs.3.00 crore or more in any one of the last 3 financial years i.e. 2018-19,2019-20 & 2020-21.		
7	Documentary proof of work order/contract agreement/work completion certificate from Govt./govt aided organization in support of experience in supplying Educational kit / Math Kits / Science kits / or equivalent Teachig or Learning materials to Govt./Govt aided organization in any one of years from 2018-19 to 2021-22. The minimum size of such a contract should have been for supply of 1000 units of any type of kit/equivalent teaching or learning materials.		
8	One set of sample Mathematics Learning Kit duly sealed, packed and authenticated (to be submitted in off-line mode)		
9	Test Report of sample Mathematics Learning Kit on Point No.5 (Material) of Item No.1 to 20 of the Technical Specification from any Govt. testing Laboratory (State Govt /Central Govt/UT Govt) or from any NABL Accredited Testing laboratory of India		
10	Test certificate confirming to IS 9873 (Part 3) or ISO 8124-3 for the materials used in the manufacturing of Mathematics learning Kit, from any Govt. testing Laboratory (State Govt /Central Govt/UT Govt) or from any NABL Accredited Testing laboratory of India.		
11	Declaration in prescribed format (Annexure-B) in shape of an affidavit before executive Magistrate / Notary Public		
12	Bid security / EMD Declaration in Tech-4 format		
13	Bid Processing fee/cost of tender paper as applicable (on-line)		
14	Properly filled in Format-Tech-1,Tech-2,Tech-3		

Place:
Date:

BIDDER/S'S OFFICIAL SIGNATORY
Name & Designation with Rubber Stamp/
Official Seal of the Firm.

(In Bidder's letter Head)

[Location, Date]

BID SECURITY / EMD DECLARATION

This is to undertake that if I/we withdraw or modify our Bids during the period of validity, or failed to sign the contract, if awarded or failed to submit a performance security before the deadline defined in the request for bids document, our organisation will be suspended for the period of 03 years from being eligible to submit Bids for contracts with the OSEPA.

Authorized Signatory [*In full and initials*]

Name and Designation of Signatory with Date and Seal:

Address of the Bidder

Section - 8

Annexures (A,B,C,D)

Annexure-A

PROFORMA FOR SUBMISSION OF AFFIDAVIT IN RUPEES OF TEN OF INDIA NON-JUDICIAL STAMP PAPER BY THE BIDDER/SS WHO ARE NOT REGISTERED UNDER ODISHA GST ACT.

I _____, Aged About _____years son of Sri _____, the Proprietor of M/S_____ do hereby solemnly affirm and declares as under:

1. That I am the deponent of this affidavit.
2. That I do hereby declare that I have not been registered under the Odisha GST Act and have not started any business in the State of Odisha till yet & we have no liability under the Odisha GST Act.
3. I am a registered dealer of the _____ State having GST No._____ and I am enrolled under the State / Central GST authority of _____ (place). I am authorized to deal in the _____, _____, _____, _____ items (quoted).
4. That I swear this affidavit to be produced before the concerned authority for future reference and record.
5. That the facts stated above are true to the best of my knowledge and belief and nothing has been concealed thereon.

Identified

Advocate

Deponent: _____
(With Seal Stamp)

Name & Address:

The above named deponent being identified by Shri _____ Advocate_____ solemnly affirm and states before me that the contents of this affidavit are true to the best of his knowledge.

Dt. _____ Executive Magistrate/Notary: _____
(With Seal Stamp)

PROFORMA FOR SUBMISSION OF AFFIDAVIT IN RUPEES OF TEN OF INDIA NON-JUDICIAL STAMP PAPER BY THE BIDDER/SS FOR DECLARATION.

(Affidavit before Executive Magistrate / Notary Public)

I / Wehaving my / our office at.....do declare that I / We have carefully read all the terms & conditions of bid floated by OSEPA, Odisha for the supply of Teaching Learning Material on Mathematics and abide by them. I will abide with all the terms & conditions set forth in the **Bid document Reference no.** _____ **dated** _____ along with the subsequent amendment, if any.

I / We agree that the Tender Inviting Authority (OSEPA) can forfeit the Performance Security Deposit and blacklist our entity for a period of **03 (three)** years if any information furnished by us is found to be false at the time of inspection / verification and not complying with the Bid terms & conditions. In case I/We are de-recognized / black listed / banned / by any State Govt. / Union Territory / Govt. of India / Govt. Organization / Govt. Institutions / PSUs / Government autonomous body, Society / OSEPA and or convicted by any court of law **on and from the date of floating of the tender**, I/We undertake to inform the same to OSEPA.

I/we also under take that, I/we are not involved in any unfair / fraudulent practice.

I/we _____do hereby undertake that the samples provided by our firm for technical evaluation is in conformity with the tendering specification and non-toxic as set forth in the Bid document vide Bid Reference no. _____ dated _____ along with the subsequent amendment, if any.

I/Wedo hereby declare that I / We will supply the TLM on Mathematics as per the terms, conditions & specifications of the bid document.

Identified

Advocate

Deponent: _____
(With Seal Stamp)

Name & Address:

The above named deponent being identified by Shri _____ Advocate _____ solemnly affirm and states before me that the contents of this affidavit are true to the best of his knowledge.

Dt. _____ Executive Magistrate/Notary: _____
(With Seal Stamp)

DISTRICT-WISE REQUIRMENT OF TLM ON MATHEMATICS

Sl. No.	Name of the Districts	Nos.
1	ANGUL	44
2	BALASORE	2091
3	BARAGARH	84
4	BHADRAK	1540
5	BOLANGIR	33
6	BOUDH	14
7	CUTTACK	1854
8	DEOGARH	8
9	DHENKANAL	40
10	GAJAPATI	61
11	GANJAM	43
12	JAGATSINGHPUR	937
13	JAJPUR	27
14	JHARSUGUDA	520
15	KALAHANDI	38
16	KANDHAMAL	112
17	KENDRAPADA	1570
18	KEONJHAR	70
19	KHORDHA	1199
20	KORAPUT	130
21	MALKANGIRI	60
22	MAYURBHANJ	119
23	NAWARANGPUR	65
24	NAYAGARH	31
25	NUAPADA	45
26	PURI	1725
27	RAYAGADA	119
28	SAMBALPUR	48
29	SONEPUR	12
30	SUNDERGARH	107
TOTAL		12746

PERFORMANCE BANK GUARANTEE FORMAT

To,

**The State Project Director
OSEPA**

WHEREAS..... (Name and address of the supplier) (hereinafter called "the supplier") has undertaken, in pursuance of contract no..... dated to supply Teaching Learning Material on Mathematics" (description of goods & services) (herein after called "the contract").

AND WHEREAS it has been stipulated by OSEPA in the said contract that the supplier shall furnish you with a bank guarantee by a scheduled commercial bank recognized by you for the sum specified therein as security for compliance with its obligations in accordance with the contract;

AND WHEREAS we have agreed to give the supplier such a bank guarantee;

NOW THEREFORE we hereby affirm that we are guarantors and responsible to you, on behalf of the supplier, up to a total of (amount of the guarantee in words and figures), and we undertake to pay you, upon your first written demand declaring the supplier to be in default under the contract and without cavil or argument, any sum or sums within the limits of (amount of guarantee) as aforesaid, without your needing to prove or to show grounds or reasons for your demand or the sum specified therein.

We hereby waive the necessity of your demanding the said debt from the supplier before presenting us with the demand.

We further agree that no change or addition to or other modification of the terms of the contract to be performed there under or of any of the contract documents which may be made between you and the supplier shall in any way release us from any liability under this guarantee and we hereby waive notice of any such change, addition or modification.

This performance bank guarantee shall be valid until the day of, 20_____

Our _____ branch at _____, Bhubaneswar, Odisha (Name & Address of the _____*branch) is liable to pay the guaranteed amount depending on the filing of claim and any part thereof under this Bank Guarantee only and only if you serve upon us at our _____* branch a written claim or demand and received by us at our _____* branch on or before Dt.....otherwise bank shall be discharged of all liabilities under this guarantee thereafter.

.....
(Signature of the authorized officer of the Bank)

.....
Name and designation of the officer

.....
Seal, name & address of the Bank & Branch